

HN62321A Series

HN62331A Series

1M (128K x 8-bit) Mask ROM

DESCRIPTION

The Hitachi HN62321A/HN62331A Series is a 1-Megabit CMOS Mask Programmable Read Only Memory organized as 131,072 x 8-bit.

The low power consumption of this device makes it ideal for battery powered, portable systems. In addition, the high speed provides enough capacity and high performance to be used as a character generator in laser printers.

Hitachi's HN62321A/HN62331A Series is offered in JEDEC-Standard Byte-Wide EPROM pinouts in 32-pin Plastic DIP and 32-lead Plastic SOP packages. This allows socket replacement with Flash Memory and EPROMs.

FEATURES

- Single Power Supply:
 $V_{CC} = 5 V \pm 10\%$
- Fast Access Times:
 120/150 ns (max)
- Low Power Consumption:
 Active Current: 100 mW (typ)
 Standby Current: 5 μ W (typ)
- Byte-Wide Data Organization
- TTL-Compatible Inputs and Outputs
- Three-State Data Outputs
- Pin Arrangements:
 JEDEC Standard Byte-Wide EPROM
 Flash and EPROM Compatible
- Packages:
 32-pin Plastic DIP
 32-lead Plastic SOP

ORDERING INFORMATION

Type No.	Access Time	Package
HN62331AP-12	120 ns	32-pin Plastic DIP
HN62321AP-15	150 ns	(DP-32)
HN62331AF-12	120 ns	32-lead Plastic SOP
HN62321AF-15	150 ns	(FP-32D)

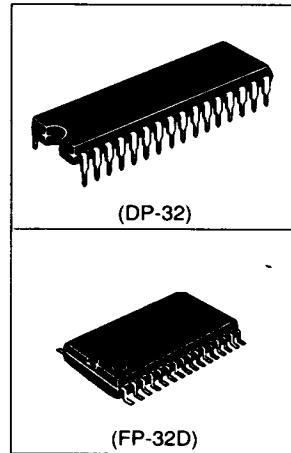

PIN ARRANGEMENT

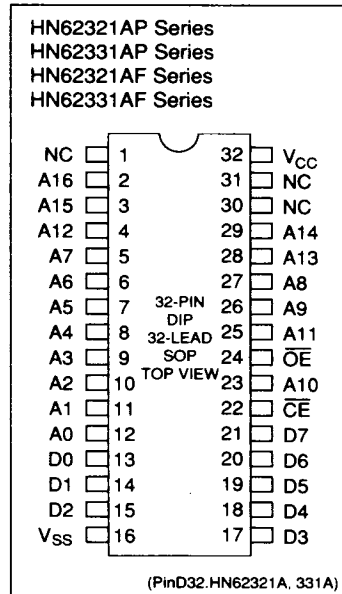

5

HITACHI

Hitachi America, Ltd. • 2000 Sierra Point Pkwy. • Brisbane, CA 94005-1819 • (415) 589-8300

5-7

■ **PIN DESCRIPTION**

Pin Name	Function
A ₀ - A ₁₆	Address
D ₀ - D ₇	Output
\overline{CE}	Chip Enable
\overline{OE}	Output Enable
V _{CC}	Power Supply
V _{SS}	Ground
NC	No Connection

■ **BLOCK DIAGRAM**

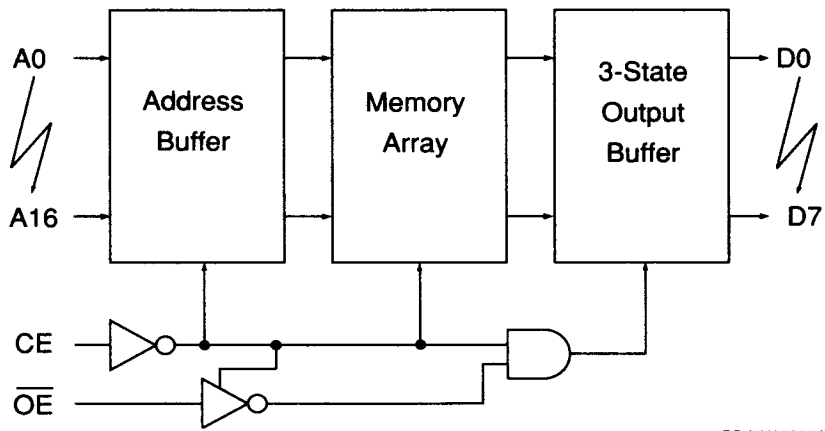

(BD.HN62321A,331A)

HITACHI

■ ABSOLUTE MAXIMUM RATINGS

Item	Symbol	Value	Unit
Supply Voltage ¹	V _{CC}	-0.3 to +7.0	V
Terminal Voltage ¹	V _T	-0.3 to V _{CC} + 0.3	V
Operating Temperature Range	T _{OPR}	0 to +70	°C
Storage Temperature Range	T _{STG}	-55 to +125	°C
Temperature Under Bias	T _{BIAS}	-20 to +85	°C

Notes: 1. With respect to V_{SS}.

■ CAPACITANCE

(V_{CC} = 5V ± 10%, V_{SS} = 0V, T_a = 25°C, V_{IN} = 0 V, f = 1MHz)

Item	Symbol	Min.	Max.	Unit
Input Capacitance ¹	C _{IN}	-	10	pF
Output Capacitance ¹	C _{OUT}	-	15	pF

Notes: 1. This parameter is sampled and not 100% tested.

■ DC ELECTRICAL CHARACTERISTICS FOR READ OPERATION

(V_{CC} = 5V ± 10%, V_{SS} = 0 V, T_a = 0 to 70°C)

Item	Symbol	Min.	Max.	Unit	Test Condition
Input Leakage Current	I _{LI}	-	10	μA	V _{IN} = 0 to V _{CC}
Output Leakage Current	I _{LO}	-	10	μA	\overline{CE} = 2.2 V, V _{OUT} = 0 to V _{CC}
Operating V _{CC} Current	I _{CC}	-	50	mA	V _{CC} = 5.5 V, I _{DOUT} = 0 mA, t _{RC} = Min.
Standby V _{CC} Current	I _{SB}	-	30	μA	V _{CC} = 5.5 V, $\overline{CE} \geq V_{CC} - 0.2V$
Input Voltage	V _{IH}	2.2 ¹	V _{CC} +0.3	V	
	V _{IL}	-0.3	0.8 ¹	V	
Output Voltage	V _{OH}	2.4	-	V	I _{OH} = -205 μA
	V _{OL}	-	0.4	V	I _{OL} = 3.2 mA

Notes: 1. HN62331A Series is V_{IH} = 2.4V (min) and V_{IL} = 0.45V (max).

■ AC ELECTRICAL CHARACTERISTICS FOR READ OPERATION

($V_{CC} = 5V \pm 10\%$, $V_{SS} = 0V$, $T_a = 0$ to $70^\circ C$)

Test Conditions

- Input pulse levels: HN62321A Series: 0.8 V / 2.4 V HN62331A Series: 0.45 V / 2.4 V
- Input rise and fall times: ≤ 10 ns
- Output load: 1 TTL Gate + CL = 100 pF (Including jig capacitance)
- Input/Output Timing Reference level: 1.5 V

Item	Symbol	HN62331A		HN62321A		Unit
		Min.	Max.	Min.	Max.	
Read Cycle Time	t_{RC}	120	-	150	-	ns
Address Access Time	t_{AA}	-	120	-	150	ns
\overline{CE} Access Time	t_{ACE}	-	120	-	150	ns
\overline{OE} Access Time	t_{OE}	-	60	-	70	ns
Output Hold Time from Address Change	t_{DHA}	0	-	0	-	ns
Output Hold Time from \overline{CE}	t_{DHC}	0	-	0	-	ns
Output Hold Time from \overline{OE}	t_{DHO}	0	-	0	-	ns
\overline{CE} to Input in High Z	t_{CHZ}^1	-	60	-	70	ns
\overline{OE} to Input in High Z	t_{OHZ}^1	-	60	-	70	ns
\overline{CE} to Output in Low Z	t_{CLZ}	5	-	10	-	ns
\overline{OE} to Output in Low Z	t_{OLZ}	5	-	10	-	ns

Note: 1. t_{CHZ} and t_{OHZ} define the time at which the output becomes an open circuit and are not referenced to output voltage levels.

■ READ TIMING WAVEFORM

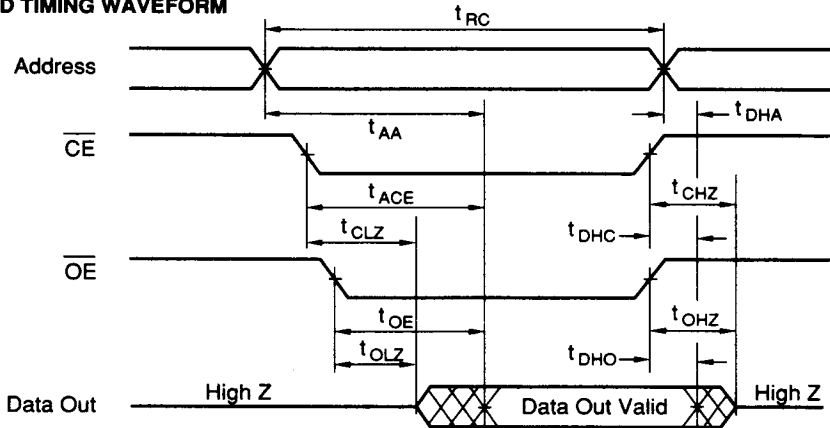

- Note: 1. t_{DHA} , t_{DHC} , t_{DHO} are determined by the faster time.
 2. t_{AA} , t_{ACE} , t_{OE} are determined by the slower time.
 3. t_{CLZ} , t_{OLZ} are determined by the slower time.

(TD.HN62321A,331A)

HITACHI