

## ALL ABOUT BUBBLE MEMORY DEVICES

ROBERT F. SCOTT  
SEMICONDUCTOR EDITOR

YOU'VE PROBABLY READ BRIEF ANNOUNCEMENTS OF NEW USES for "bubble memory" devices or watched as a TV science reporter demonstrated some futuristic device that would soon be made possible through the use of bubble memory. If this has given you the impression that bubble memory is a new revolutionary technology or a science-fiction-like development that will never touch your personal life, you're dead wrong! Certainly you've misdialled a telephone number and heard the following announcement: "We're sorry. Your call did not go through. Please check the number and dial again or ask your operator for assistance." This is an example of bubble memory in speech synthesis and telephone switching.

The patent covering the discovery of the magnetic bubble and the fact that bubbles can be generated, replicated and erased was granted to Bell Laboratories scientists Richard C. Sherwood, William F. Schockley, Umberto F. Gianola, and Andrew H. Bobeck way back in 1966. An article in the Bell Labs *Record*, June/July 1970 announced that magnetic bubbles can be used to record, store and read data simply by applying and manipulating external magnetic forces. The presence or absence of a bubble at a given location represents a logic "1" or "0", respectively.

In the November 1976 issue of the *Record*, Bell Laboratories announced a voice-message recorder using bubble memory technology. The analog message is encoded into a digital format and stored in the bubble memory until needed. The digitally stored data can be read out, decoded and converted back into the original voice announcement. Twelve seconds of digitized voice or twelve pages of single-space typewritten text containing 280,000 bits of data can be stored on a single 10-mm by 10-mm square chip. This puts the chip in the same class as a 250K bit memory with 64K bytes of memory storage.

The magnetic bubble memory (MBM) combines the read/write features of RAM's, the non-volatility of ROM's, and is competitive in storage capacity with tape and disk systems. Table 1 compares the performance advantages and disadvantages of bubble memories with ROM's, PROM's, RAM's, and floppies.

### What is a bubble?

Essentially, magnetic bubbles are formed in a thin magnetic material that is polarized. Each magnetic bubble is a microscopic magnetic cylinder of reverse polarization to that of the thin

TABLE 1

ADVANTAGES		DISADVANTAGES
Higher reliability Non-mechanical Smaller size Faster access Simpler interface Media integrity	<b>Bubble memory vs Floppy disk</b>	Stored data not readily changed
Non-volatile More bits per device Reduced board space	<b>Bubble memory vs RAM</b>	Slower access Slower transfer rate
Programmability More bits per device Less board space	<b>Bubble memory vs ROM or PROM</b>	Slower access Slower transfer rate

magnetic substance that surrounds it. These bubbles are the individual memory cells in the "bubble memory" that are comparable to the individual memory cells in a conventional semiconductor memory element. The important point is that physically, they are much smaller and therefore a lot more memory capacity fits into the same amount of space. Now let's take a look at how these devices are fabricated.

The approximately 1/4-inch square bubble memory chips are fabricated onto 3-inch diameter single-crystal epitaxial garnet wafers. The wafers have two layers: a non-magnetic gadolinium gallium garnet (GGG) substrate about 0.015-inch thick supporting a grown film of magnetic garnet. (The film is 3 micrometers thick—about 120 millionths of an inch—and is composed of yttrium samarium calcium iron garnet.) Each 3-inch wafer can be sliced to yield up to 44 chips.

When the magnetic film is formed, it is magnetized at right angles to its surface so that regions of both North polarization and South polarization exist. The magnetic regions (see Fig. 1-a) are serpentine in shape and the surface areas of the North and South polarizations are equal in total size.

When an external magnetic field (bias field) is applied perpendicular to the film surface, magnetic regions having the same polarization as the bias field expand. At the same time, regions with reverse polarization shrink. As the intensity of the magnetic bias is increased, magnetic regions of the reverse polarization shrink until they become microscopic magnetic cylinders ("bubbles") as shown in Fig. 1-b.

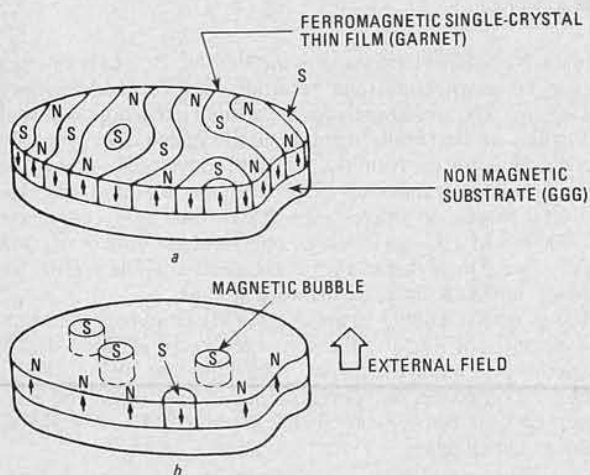

Fig. 1—WITHOUT EXTERNAL MAGNETIC FIELD the "S" and "N" magnetic domains have equal surface areas so the effective magnetic moment is zero (a). When external magnetic field (b) is applied, domains having opposite polarity shrink into microscopic magnetic cylinders called "bubbles".

The bubbles are 3 μm in diameter and are stable within a given range of bias intensity. Above this range, bubbles suddenly collapse and disappear. Below this range, they spontaneously return to the original serpentine-shaped magnetic regions.

In bubble memories, built-in permanent magnets are used to provide the correct bias intensity. Thus bubble memories are non-volatile—that is, information is not lost if electrical power is interrupted.

Variable electromagnetic fields parallel to the film's surface are used to move the bubbles laterally (like hockey pucks) around in the film. The ability to generate and manipulate magnetic bubbles is the basis for the bubble memory device. The presence of a bubble at a given location represents a logic 1; the absence of a bubble represents a logic 0.

In practice, the varying electromagnetic field is generated by a pair of electromagnetic coils wound around the chip at right angles to each other and fed triangle-waveform currents that are 90° out-of-phase. This produces a rotating electromagnetic field that propels the bubbles along a "propagation" track formed from thin-film patterns of Permalloy—a soft nickel-iron mag-

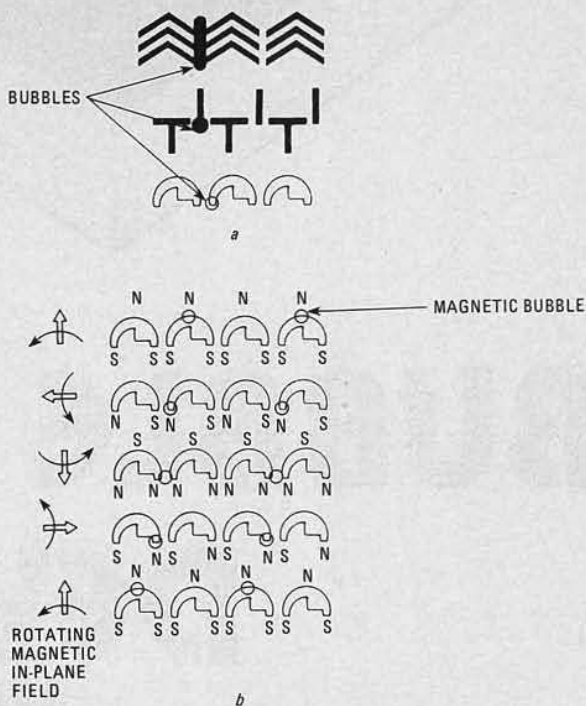

Fig. 2—PROPAGATION TRACK is made of a soft ferromagnetic material shaped as chevrons, T-bars or asymmetrical half-circles as shown in a. The rotating magnetic field changes the instantaneous magnetic polarity of the track elements; causing the bubbles to move down the track as in b. In this instance, the bubbles have "S" polarity and are attracted to "N" or North poles of the track elements.

netic material—laid down in the form of T-bars, or asymmetrical "chevrons" or semicircles. See Fig. 2. The bubbles move along under the chevrons; jumping from one to the other as the polarization of the rotating bias field changes. The bubble moves one stage along the pattern for each 360° revolution of the magnetic field.

Figure 3-a shows how a simple rectangular propagation track of chevrons can be laid out on the magnetic garnet film. In practice, the track can follow various paths. One approach is a track that is compactly folded back and forth across the chip. The bubble stream is kept in continuous motion, passing a "write" head at one point and a "read" head at another point. Data is read as the bubbles make a full revolution around the track.

Figure 3-b shows the basic construction of a magnetic bubble memory device. The chip is surrounded by two right-angle coils



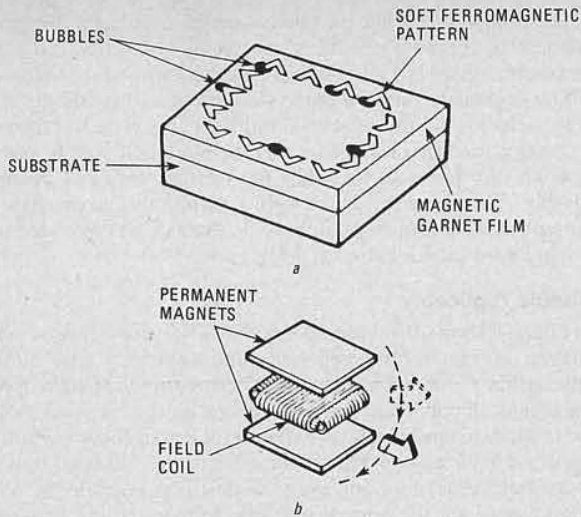

Fig. 3—PERMALLOY CHEVRONS shown in a are placed on the garnet film/by using printed-circuit techniques. They are energized by the magnetic field from a pair of crossed field coils (b) fed out-of-phase AC voltages.

to provide the rotating magnetic bias field to drive the bubbles. Thin rectangular permanent magnets are added top and bottom to develop the perpendicular bias field to generate and sustain the bubbles. These permanent magnets preserve the bubbles in the memory; even when the rotating magnetic field is removed or power sources fail. This characteristic makes the bubble memory as non-volatile as disks or tape. In addition, the permanent magnets provide a permanent magnetic field of such strength that bubbles can easily be generated, sustained, and erased.

To make full use of magnetic bubbles as a memory device, we must be able to erase or "annihilate" old bubbles, generate new ones, "replicate" existing bubbles into two new ones, transfer selected bubbles from one track or loop to another, and detect the presence or absence of a bubble at a given location and point in time.

#### How bubbles are generated

The bubble generator most often used is a "hairpin" conductor loop inserted between the garnet film and a special "pickax" shape Permalloy chevron on the propagation track. See Fig. 4. When a pulse of current is passed through the "hairpin" loop, it generates a magnetic field opposite to the bias field in the direction that causes a bubble to form. The bubble is

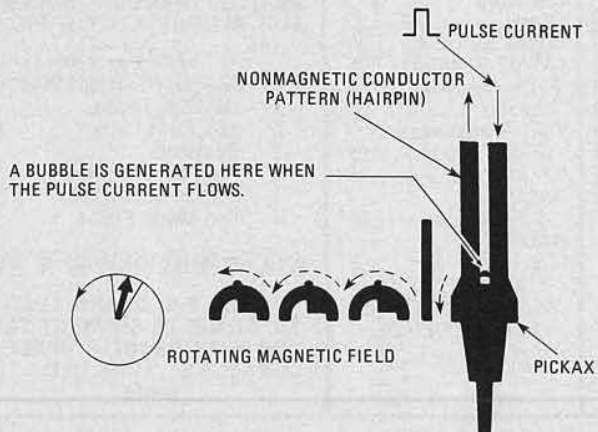

Fig. 4—A NONMAGNETIC HAIRPIN is placed between the film and a Permalloy pattern. Bubble forms if hairpin is pulsed while rotating field is oriented as shown.

then rapidly passed along the track by the rotating magnetic field. This process is repeated as data is written bit-by-bit and

stored in memory.

#### Switching bubble direction

Bubbles are transferred from one track to another by a Permalloy pattern (Fig. 5) similar to the bubble generator. If the "hairpin" is pulsed when the rotating magnetic field is as shown, the bubble approaching from the right is inhibited from moving leftward and is diverted upward onto the intersecting track. Here's how it works. When a bubble is located at the right "pickax" point and a pulse of current is fed through the "hairpin", field polarities momentarily block further movement to the left and the bubble is diverted into the upper path by action of the rotating magnetic field.

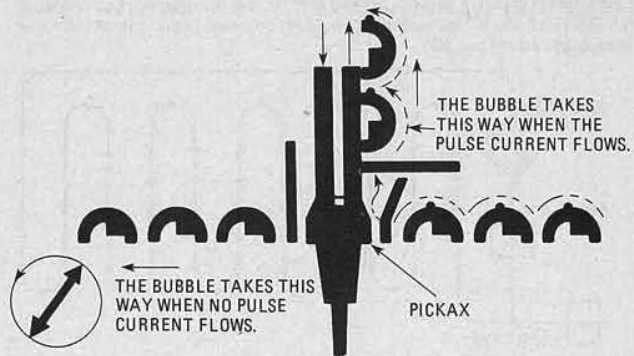

Fig. 5—PATTERN FOR CHANGING BUBBLE DIRECTION is similar to bubble generator. If current pulse is fed to hairpin when direction of rotating field is as shown, bubble is diverted upward and inhibited from leftward movement.

#### Bubble eraser

The method for erasing a magnetic bubble uses the same technique for switching the direction of a magnetic bubble. Instead of being shifted into or from a secondary storage loop, the bubble is removed from the storage loop and erased by an electromagnetic pulse of proper polarity.

#### Bubble detection

Bubble detection for data recovery can either be destructive (the bubble is destroyed and does not remain in the storage bank) or nondestructive (the bubble remains in the memory). Replication or bubble division is used in nondestructive detection. One bubble continues along the normal path and remains in storage; the other is diverted to the detector and then erased.

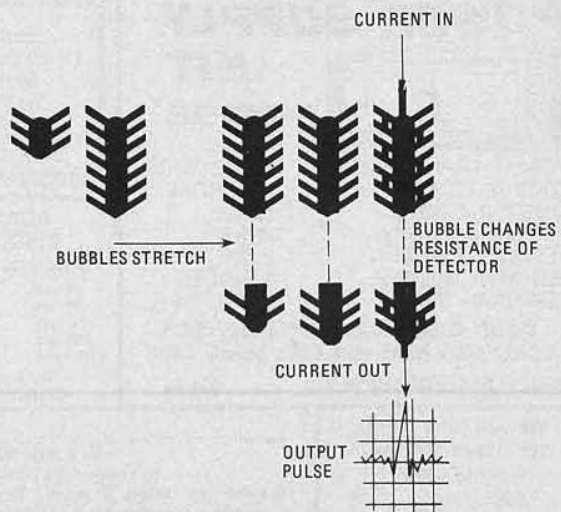

Fig. 6—BUBBLES ARE ELONGATED as they move from one "stretcher" pattern to the next. Bubbles are stretched to provide higher output from the Hall-effect detector.

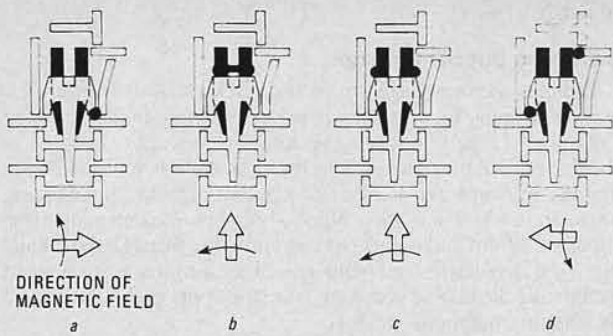

Fig. 7—BUBBLE REPLICATOR or splitter stretches bubble when rotating field angle is at (b) If hairpin is pulsed at this time, bubble splits as shown in (c). The two bubbles leave and move along different propagation tracks as field angle advances 90°.

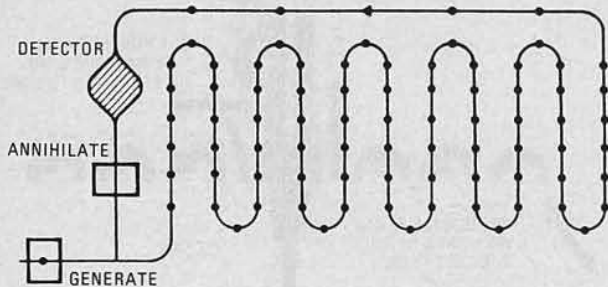

Fig. 8—THE BASIC BUBBLE MEMORY uses a serial-loop shift-register configuration. Access (or data-recovery) time is long because the data to be read must circulate through the entire loop.

The bubble to be read passes under several rows of symmetrical chevrons (Fig. 6) which causes the bubble to stretch so its length is several hundred times the normal diameter. This

much-elongated bubble is passed under a pattern of series-connected chevrons made of a special Hall-effect (magneto-resistive) material. (Hall-effect materials are those conductors whose resistance varies with the strength of a surrounding magnetic field.) A current of several milliamperes is passed through the magneto-resistive detector. As the stretched bubble passes through the detector, it causes the device resistance to drop sharply. This increases current flow sufficiently to produce an output pulse, of around 10 millivolts, that can be converted into a standard digital electronic pulse.

#### Bubble replicator

Figure 7 shows the replication process. It is based on the same pattern as the bubble generator and switcher. The bubble approaching from the right is elongated or stretched at the top of the pickax. It splits into halves when the hairpin is pulsed while the rotating magnetic field is in the angular area encompassed by the directional arrows. One of these bubbles is diverted upward to the bubble detector and eventual destruction while the other continues along the normal path and remains in the memory.

#### Bubble memory architecture

The basic bubble memory configuration is a simple serial loop shift register as illustrated in Fig. 8. This system has several disadvantages. One of the major ones is that access time is long because bubbles must circulate through the entire string of chevrons before they can be read. Access time can range from 370 to 750 ms. Another disadvantage is that perfect operation depends on a near-perfect device. Defects in substrate, garnet film, or the etched chevron pattern decrease production yield and increase cost. For these reasons most bubbles memories use architecture (system designs) that have much shorter access times and allow for many defects in chip geometry. These will be discussed in a following issue.

R-E

## 2300 MHz VARIABLE DOWNCONVERTER

### ANTENNA KIT

\$16.95

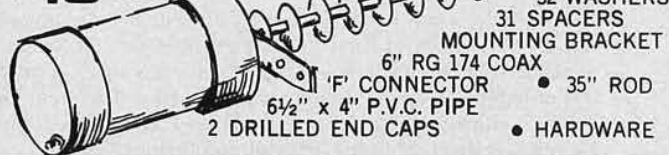

- 32 WASHERS
- 31 SPACERS
- MOUNTING BRACKET
- 6" RG 174 COAX
- 'F' CONNECTOR
- 6 1/2" x 4" P.V.C. PIPE
- 2 DRILLED END CAPS
- 35" ROD
- HARDWARE

### POWER SUPPLY KIT

\$16.95



- POWER TRANSFORMER
- COURSE TUNE POT.
- FINE TUNE POT.
- 3 'F' CONNECTORS
- RESISTORS & CAPS
- LED WITH HOLDER
- TERMINAL STRIP

- P.C. BOARD
- RF CHOKE
- KNOB
- WIRE
- 2 SWITCHES
- 4 DIODES
- LM 317 REG.

WOOD GRAIN CABINET WITH SILK SCREENED front and back \$10.95 Extra  
BUILT POWER SUPPLY.....\$34.95

Complete Down Converter System  
INCLUDES ANTENNA KIT  
POWER SUPPLY KIT  
CONVERTER KIT  
**SPECIAL \$49.95**

**QUANTITY DISCOUNTS**  
Any Price in Adv.

10 pcs.	12% off
25 pcs.	18% off
50 pcs.	25% off
100 pcs.	30% off
1000 pcs.	35% off

No Mixing for Quantity Discount

### PARTS

- Converter P.C. Board Plated through holes for stability.....\$4.95
- Power Supply
- P.C. Board .....2.95
- MRF 901 .....2.00
- NEO2135 .....4.95
- 2835 Diodes ..... .95
- .001 Chip Caps. .... 10/3.95
- Choke Set of 4.....1.95
- LM 317 Regulator 1.25
- 'F' Connectors
- Chassis ..... .50
- Wall Transformer
- 12 VAC 700 MA....4.95
- 'U' Bolt .....95
- BALUN
- 75 to 300 ohm.....1.95
- BALUN for rabbit ears....2.95
- \*RG 59/U COAX WITH CONNECTORS
- FACTORY MADE
- 100 Ft. ....\$17.50
- 50 Ft. .... 9.50
- 25 Ft. .... 5.75
- 3 Ft. .... 2.50

### CONVERTER KIT

\$16.95



P.C. BOARD PRE-DRILLED SOLDER PLATED WITH PLATED THROUGH HOLES FOR A MORE STABLE PICTURE.

- NEW!!
- ... 2137 HOT TRANS...
- 3 MRF 901 TRANSISTOR
- 2 HP 2835 Diodes
- 6 .001 Chip Caps.
- 9 Resistors
- 4 Prewound chokes
- 1 Electrolytic Cap.
- 1 Pre Made Probe

\*WIRED P.C. BOARD TESTED, READY TO CONNECT TO CAN WITH PROBE & CABLE CONNECTOR ATTACHED.  
\$24.95

We will tune converter board for \$12.50  
trouble shoot add .....7.50  
trouble shoot power supply. \$12.50  
plus any parts needed.

We will accept collect calls for orders only on Visa and Master Card  
No C.O.D. Orders  
To Order Call 1-317-255-7776  
Complete Kit Weighs 5 pounds. Please add Sufficient Postage  
**6950 NORTH MICHIGAN ROAD**  
**INDIANAPOLIS, IN 46268**

**ELECTRONIC RAINBOW**